



Manufacturer of Electric Heating Elements and Controls

Mica Band Heaters



Mica Band Heaters are constructed by winding a nickel-chrome resistance ribbon around mica insulation and encapsulated in a stainless steel sheath. It is then formed to the desired diameter for installation over a dies, barrels and nozzles. They are available in an extensive variety of sizes and shapes with options for holes, notches and cut-outs. A number of threaded terminals, wire lead options and terminal boxes offer great flexibility for field wiring. With temperature capabilities of up to 350°C, these heaters are ideal for plastic processing applications and for anywhere heat is needed on a round or curved surface.

WATT DENSITY

The following information will help you understand watt density in order to select the proper wattage for your application. Wattage will affect the durability and performance of your heater. To prevent heater failure, do not exceed the maximum recommended watt density for a specific heater size.

$$\text{Watt density (W/in)} = \frac{\text{WATTAGE.....}}{(3.14 \times \text{Inner Diameter} \times \text{Width}) - (\text{Cold Section})}$$

VARIOUS CONSTRUCTIONS

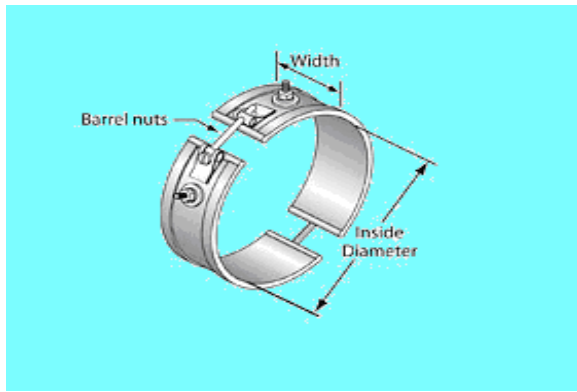

2 Pieces Construction - Ease of installation in difficult locations Recommended for diameters larger than 380mm. Available with any termination or clamping styles.

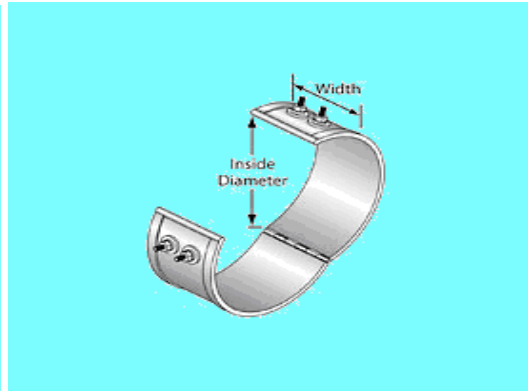

Expandable or Hinged - One piece construction used where heater cannot be slid over the barrel or die. Two sets of terminals required. All terminations available.

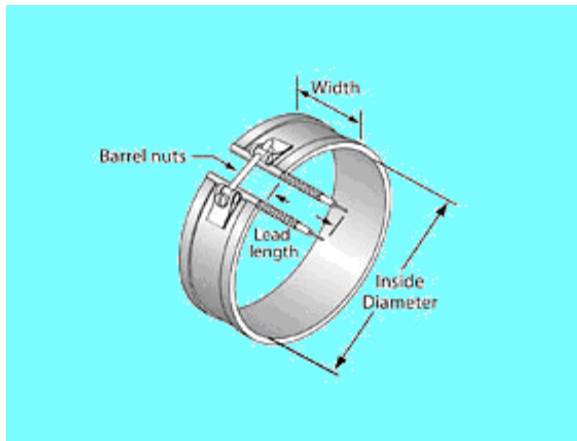

Nozzle Style - Fibreglass leads with metal over braided 300 long is standard.

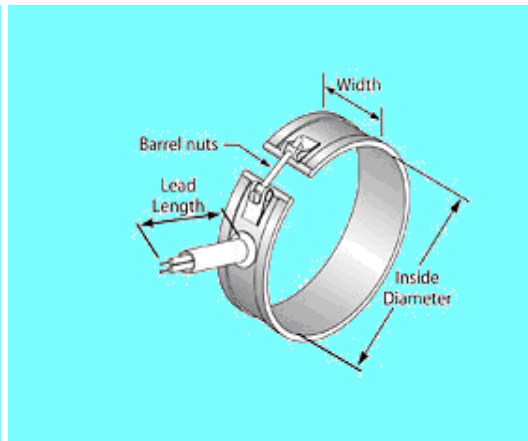

Fibreglass Leads with Protective Sleeve - Specify location and length of leads at time of order.

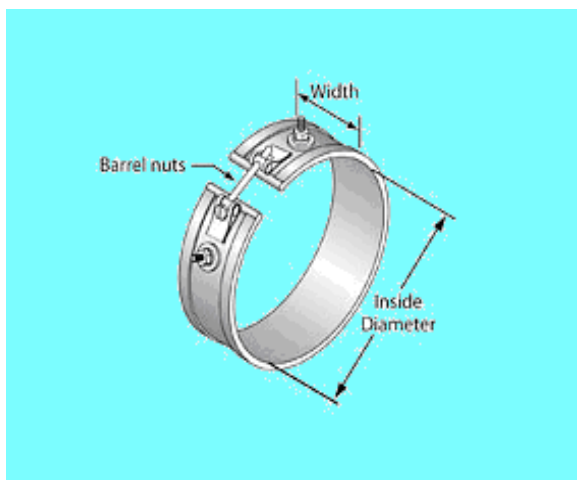

M5 Threaded Terminals - Minimum width required 20mm.

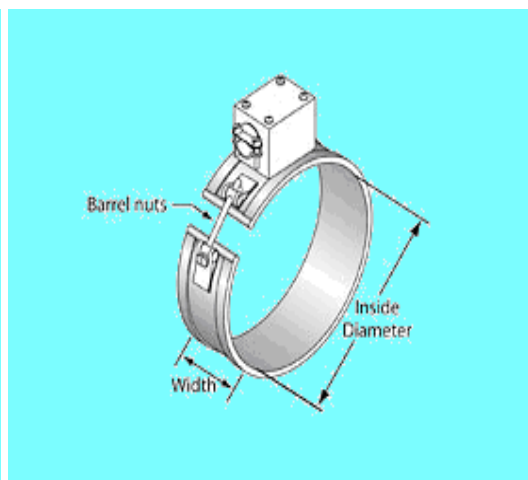

Sheet Metal Terminal Box - Available with M4 and M5 threaded terminals.



Manufacturer of Electric Heating Elements and Controls

Ceramic Band Heaters



Ceramic Band Heaters offer longer heater life, high processing temperature capabilities and full flexibility for ease of installation. The built in thermal insulation limits heat losses and conserves electrical energy. A wound nickel chrome resistance wire is strung through high temperature ceramic bricks that sit on an insulation blanket of ceramic fibre insulation. The insulation blanket will reduce heat losses by approximately 20% from un-insulated band heaters. Ceramic Band Heaters offer temperatures to 600°C. This is all mounted into a stainless steel casing with serrated edges. This provides strength and great flexibility such that the heater can be fully opened for ease of installation. Ceramic Band Heaters transmit heat both through conduction and radiation. Due to this effect, the fit is not as critical as with other types of band heaters. These are available with a number of lead wire options, threaded terminals, terminal boxes and European plugs for electrical wiring. They can be made in a large variety of sizes, multiple segment and clamping styles.

VARIOUS TERMINATIONS

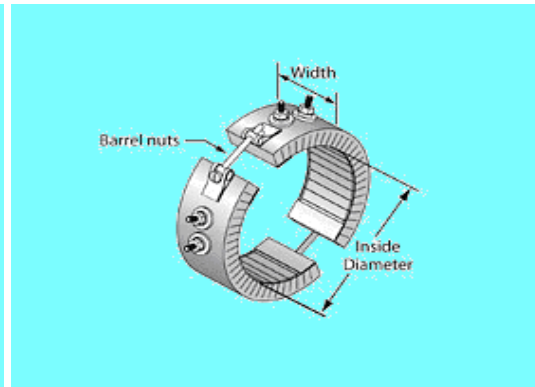
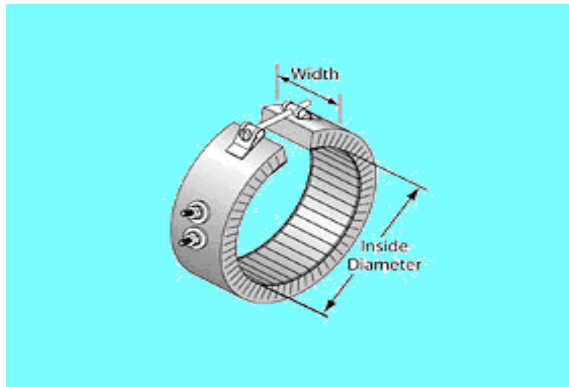

Built-in Strap - Barrel nuts provide secure and strong clamping. Also available in spring loaded designs for larger diameters

2 Pieces Construction - Ease of installation in difficult locations. Recommended for diameters larger than 380mm.

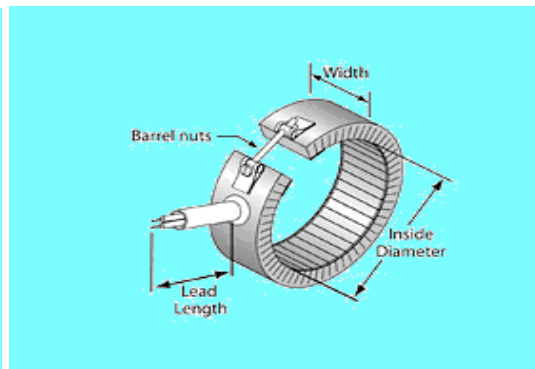
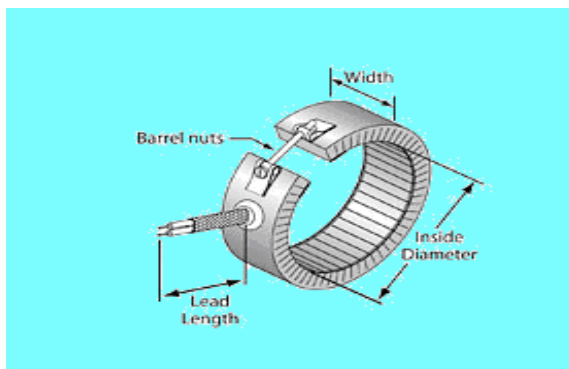

Metal braid with fibreglass leads - Specify location and length of leads at time of order.

Fibreglass leads with protective sleeve - Specify location and length of leads at time of order.

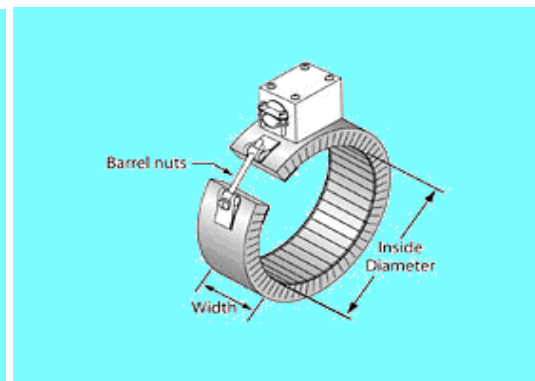
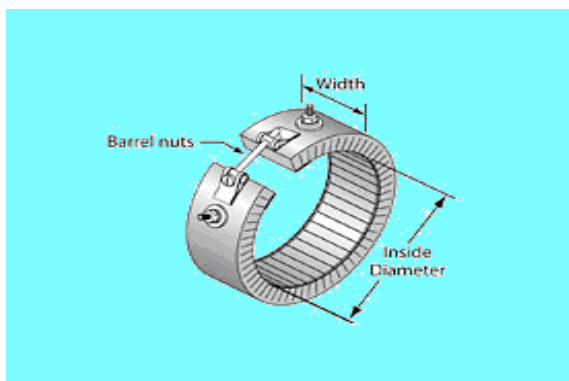

M5 Threaded Terminals - Minimum width required 20mm.

Sheet Metal Terminal Box - Available with M4 and M5 threaded terminals.

OPERATING TEMPERATURES

Mica insulated heaters operate best and provide the longest life when the sheath temperatures are held below 250°C.

Applications

- Plastic processing Machinery.
- Injection and Blow Moulding.
- Extruders.
- Many other Applications. (Medical, Lab-equipments...etc)

Features

- Rust resistant Sheath.
- Top quality Nickel Chrome ribbon.
- Max. 25 watts per sq. Inch.
- Max. Operating temperature up to 350°C

GENERAL FEATURES:

The **Ceramic band heaters**, because of their multiple uses, electric heaters are made of thermal insulating dielectric insulating material (**ceramic fibre**) which are joined together inside of which is interposed a resistive circuit made of spirals of wire alloys special high quality, which makes them suitable for all heating applications in contact, for higher temperatures, being coated with a metallic structure that protects against external shocks.

In relation to their application and the required temperatures, these *Ceramic band heaters* are able to better express their full potential.

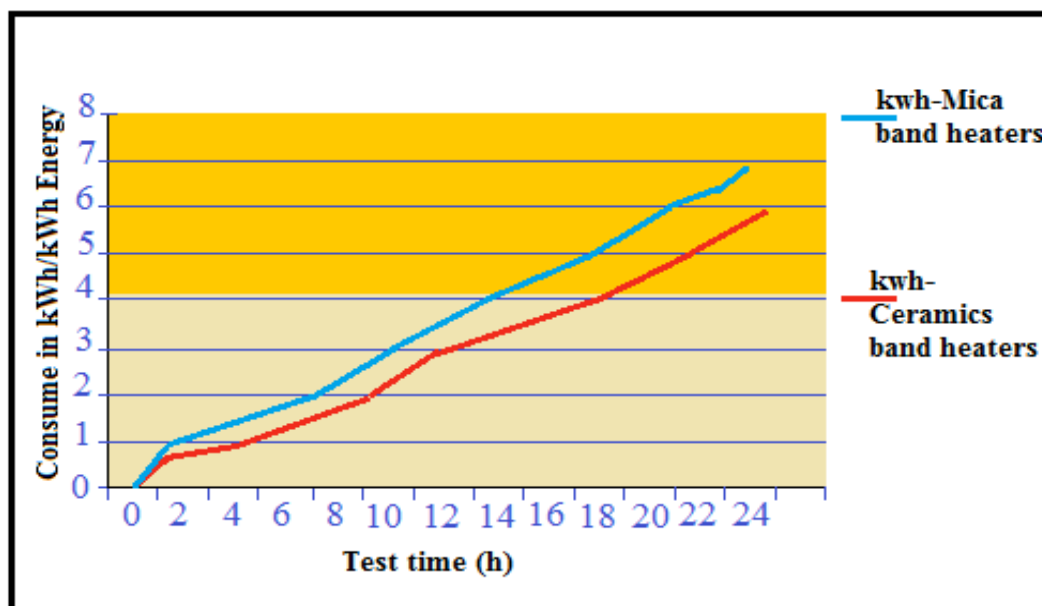

- High heat and limited time to reach the required temperature range, due to the fact that they work in direct contact with the surface to be heated.

- For specific requirements is also possible to create multi-distribution circuit, or where the total power required on-board barrel is divided between several heaters heater connected to each other.
- Very robust
- Differentiation of temperature / power on the surface.
- Good thermal insulation
- Practical mounting / installation using hooks and springs.
- Integration of temperature sensors
- Easy cleaning and maintenance

Uses:

The application of a resistance band are a function of media type and temperature that will host that will endure.

Typical applications of this heater are:

- Extruders and melting plastic, plastic injection nozzles, nozzle casting
- Storage drums, pipes, hot water boilers
- Sterilizers, machines for the confectionery industry, wood processing machines, packaging machines and packaging machines for the textile industry
- Button dies and mould for the rubber processing
- Protect from freezing liquids
- Dissolution of solids with low melting point such as paraffin, various resins and chocolate
- Control of the viscosity of fluids paint and / or foods (syrups and honey)

Technical specifications:

- Voltage: **230V (standard) or 120V up to 600V (non-standard)**
- Power: **500 to 5000W**
- Surface density: **max. 6W/cm²**
- Armour Chrome and Stainless Steel corrosion resistant
- Temperature: **max. 600-650 ° C**
- Mounting: All models are supplied with springs and hooks for easy installation on resistant trees.
- Power: All models are supplied with power cables with standard lengths of silicone fibre glass (3 x 1 L = 1.0 meters), complete with plug electrical cables, or depending on specific application needs.
- Temperature Control Devices: Upon request, the *ceramic band heaters* are supplied complete with integrated temperature control devices are compatible for installation on drums / barrels of steel or plastic material, such as fixed thermostat bimetal thermostat limiter, fixed thermostat and integrated temperature limiter, adjustable thermostat from 0 to 300 ° C or thermocouples.
- To determine the total power needed to reach the temperature of the fluid / material to be heated, which can also result from the sum of a given number of heaters heater installed in the airplane must be taken into due consideration the material of the container to be heated and the physical Fluid and chemical / material contained therein.